

STUDENT VERSION

A Study of Cholera Transmission

Urmi Ghosh-Dastidar
Mathematics Department
New York City College of Technology, CUNY
Brooklyn NY USA

Abstract: A recent cholera outbreak in Haiti brought public attention to this disease. Cholera, a diarrheal disease, is caused by an intestinal bacterium, and if not addressed in a timely manner may become fatal. During the project described here, the students will learn how to solve and address a practical problem such as cholera transmission using various mathematical tools. Students will learn to develop a differential equation model based on practical scenarios, analyze the model using mathematics as well as numerical simulation, and finally describe the results in words that are understandable by the people who are not specialists in this field. The goal of our differential equation model activity is to describe the cholera disease dynamics by a set of differential equations, find disease-free and endemic equilibrium points (if any exist), perform a stability analysis of the equilibrium points by using the Jacobian, and describe the disease dynamics by using numerical simulation. The effect of seasonality in pathogen transmission including an endemic disease as well as new outbreak cases can be added as an extension of this project for undergraduate research activities. This model is an extension of a general waterborne pathogen model.

Keywords: cholera, infectious disease, disease-free equilibrium, endemic equilibrium, transmission rate.

Tags: System, differential equations, nonlinear, waterborne pathogen, stability.

STATEMENT

The pathogenic bacterium, *Vibrio cholera*, is found in the feces of infected people. It is usually spread when an infected person transmits pathogens into the drinking water or contaminates food. Although person-to-person cholera transmission may occur via food handling [3], for simplicity we will ignore the human-to-human transmission path and focus only on transmission via water. Cholera is still a major problem in developing countries, but if hygiene is maintained properly this disease can be contained easily. However, if neglected or not addressed properly, cholera can be fatal [1, 2, and 9].

If interested, teachers may consult [5, 8, 10, and 11] for further study on the transmission modeling of cholera. A typical disease dynamics diagram based on cholera transmission is presented below.

We start with a variation of the SIWR (Susceptible S –Infectious I –Waterborne Pathogen Concentration W –Recovered R) model proposed by Tien and Earn [10] and the model proposed by Ghosh-Dastidar and Lenhart [5]. The term $V(t)$ represents the rate of susceptible individuals being vaccinated per unit of time. We assume the infection is transmitted mainly via the waterborne pathogens at rate b_w . The natural birth and death rates are assumed to be equal and given as μ . The vaccination procedure for cholera requires two doses of vaccines for complete temporary immunity, and only those persons who receive two-doses of vaccines are included in the recovered class. Additionally, we assume the vaccine provides the same strength of immunity as possessed by those individuals who have recovered naturally. All immunity to cholera is assumed to wane at rate ω . All disease related recoveries occur at rate γ . Furthermore, the infected individuals are assumed to shed pathogens in water at rate α and pathogens decay in water at rate ζ . A schematic diagram of the disease transmission is provided in Figure 1.

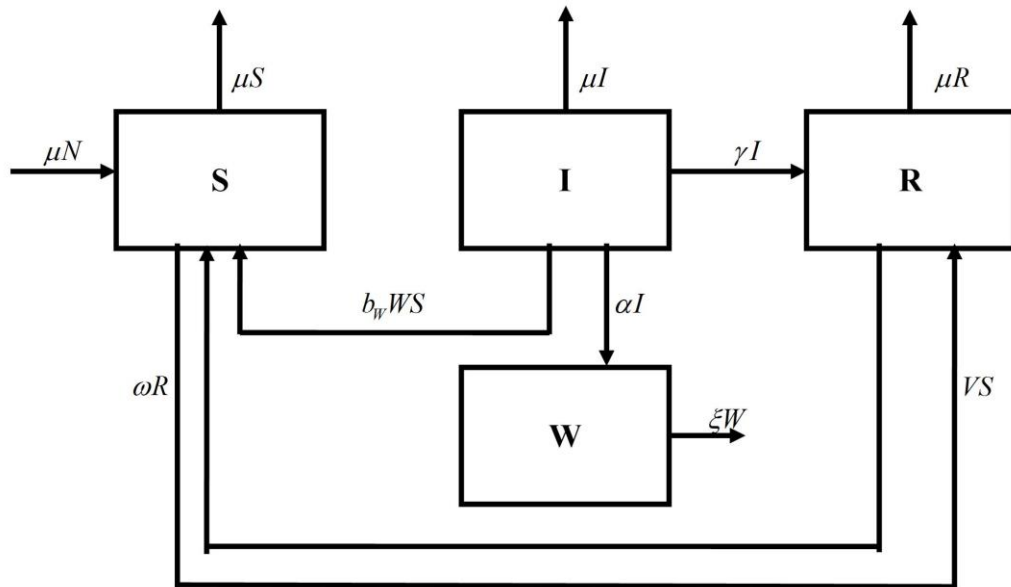

Figure 1 Flow diagram of the SIWR model.

1. Use the state system with states S , I , W , and R shown in the above diagram to write a set of differential equations that correctly represent the disease dynamics.

For the problems from 2 to 6 that follow, use a fixed value for $V = V(t)$. These values will be provided by the teacher.

2. Find the equilibrium points, disease-free, and endemic equilibrium points. Describe these points.

3. Write a computer code to simulate this process using the parameter values that are provided (see Table 1). Suggested initial values are given in Table 2. These values are chosen based on literature search [5].

4. Write a computer program to represent the disease propagation.

a. Show the infectious population, $I(t)$, susceptible population, $S(t)$, and recovered population, $R(t)$ for a two-year period, and graph I , R , and S in the same window. In a separate window, but on the same page, graph the dynamics of waterborne pathogens $W(t)$ for a two-year period. Use two different initial conditions to plot these graphs. Do not forget to add a title, x and y -axis label, and legends.

5. Discuss the results of (1) – (4).

6. Can you characterize the equilibrium points just by observing the behavior of the graphs?

7. Perform a local stability analysis by linearizing the system at each equilibrium point (Hint: you need to find the Jacobian).
8. Use your answer from problem (7) to state if the equilibrium point is stable or not.
9. Summarize your results from problems (1) – (8) and write conclusions.
10. Cholera is a highly seasonal disease. Add the following seasonality term to your model, and repeat (4) with different initial conditions. Write a conclusion based on your observations for seasonal disease dynamics.

Seasonality in waterborne pathogen transmission may be given by the following function:

$$b_w(t) = B' \left(1 + A' \cos \left(\frac{2\pi(t-t_1)}{T} \right) \right)$$

A' = Amplitude of the seasonality of $b_w(t)$, B' = Average value of $b_w(t)$,
 T = Disease duration

The following figure shows seasonal dynamics of waterborne pathogen transmission that peaks during the summer months [5].

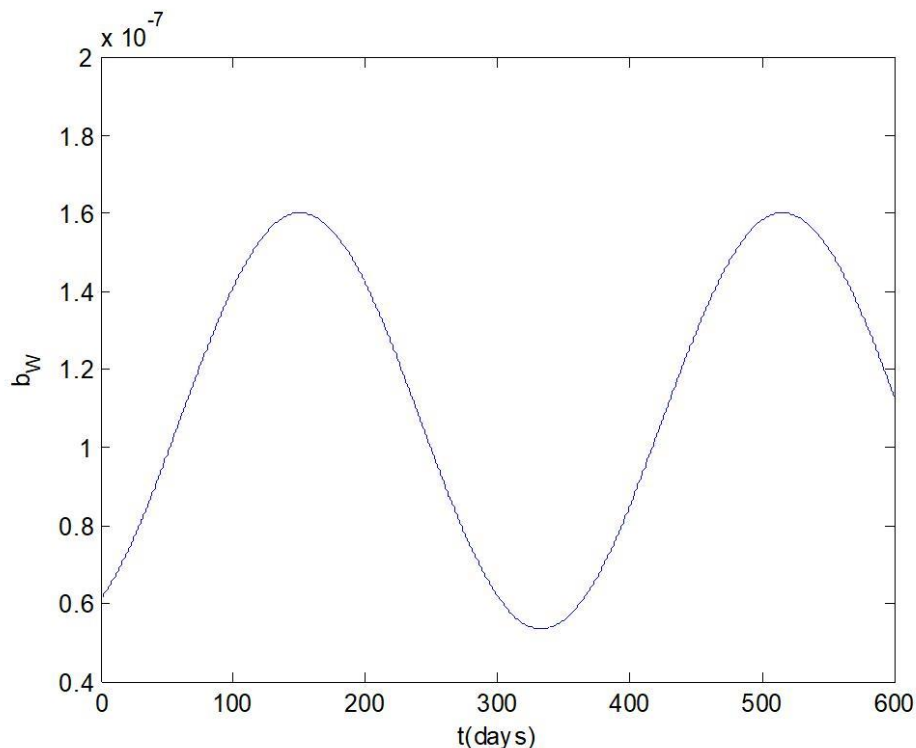

Figure 2 Seasonality of waterborne pathogen transmission rates.

Descriptions of parameters and parameter values based on a literature search [5] are provided below in Table 1:

I : Infectious state

b_w : transmission coefficient from waterborne hyperinfectious pathogens to humans

g : disease recovery rate

m : natural death and birth rate

a : pathogens shedding rate by infected individuals

χ : decay rate of less infectious pathogen rate

w : disease related waning immunity rate

Parameters	Definition	units	endemic	introduced
μ	natural death rate natural birth rate	day ⁻¹	0.033/365	0.033/365
ω	immunity waning rate	day ⁻¹	0.7/365	0.7/365
γ	recovery rate	Individuals ⁻¹ day ⁻¹	$\frac{1}{3} \approx 0.33$	$\frac{1}{3} \approx 0.33$
d	disease-related death rate (symptomatic)	Individuals ⁻¹ day ⁻¹	4.662/365	4.662/365
α	rate of pathogen shedding into reservoir	Cells ml ⁻¹ day ⁻¹ individuals ⁻¹	$\frac{3650}{365} = 10$	$\frac{3650}{365} = 10$
ξ	mean pathogen lifetime in water reservoir	day ⁻¹	1/14	1/7
b_w	transmission rate for water-to-person	ml cells ⁻¹ day ⁻¹		
T	disease duration	days	365 600 (seasonal)	365 600 (seasonal)
A'	amplitude of seasonality of $b_w(t)$	-	0.5	0.88
B'	average value of $b_w(t)$	ml cells ⁻¹ day ⁻¹	$\frac{3.9 \times 10^{-5}}{365}$	$\frac{2.14 \times 10^{-5}}{365}$
t_1	time of maximum seasonal transmissibility	days	151, May 31	151, May 31

Table 1 Parameter Values of the model

	Initial conditions	
	Endemic	Introduced
S Susceptible individuals	49900	100000
I Infected individuals	100	0
R Recovered individuals	50000	0
W pathogens concentration in water (cells ml ⁻¹)	650	15000

Table 2 Initial conditions used for simulations of the model

REFERENCES

1. Albert MJ, Neira M, and Motarjemi Y. 1997. The role of food in the epidemiology of cholera. *World Health Stat Q.* **50**:111–118.
2. Cholera prevention and control, *Center for Disease Control and Prevention*, <https://www.cdc.gov/cholera/prevention.html>. Accessed 19 April 2020.
3. Cholera epidemic associated with raw vegetables — Lusaka, Zambia, 2003–2004, Morbidity and Mortality Weekly Report. *Center for Disease Control and Prevention*. <http://www.cdc.gov/mmwr/preview/mmwrhtml/mm5334a2.htm>. Accessed 19 April 2020.
4. Edwards CH and Penney DE. 2004. Differential Equations and Boundary Value Problems. *Computing and Modeling*, 3rd ed. Pearson Education, Inc., p. 367.
5. Ghosh-Dastidar U and Lenhart S. 2015. Modeling the Effect of Vaccines on Cholera Transmission. *Journal of Biological System.* **23**: 323–338.
6. Hethcote HW. 2000. The Mathematics of Infectious Diseases. *SIAM Review.* **42**(4): 599-653.
7. Hunt BR, Lipsman RL, Osborn JE, Rosenberg JM. 2005. *Differential Equations with Matlab, 2005. 2nd Edition*. John Wiley and Sons, Inc. p 224-229.
8. Neilan RLM, Schaefer E, Gaff H, Fister RK, Lenhart S. 2010. Modeling optimal intervention strategies for cholera. *Bulletin of Mathematical Biology.* **72**:2004–2018.
9. Rabbani GH and Greenough WB 3rd. 1999. Food as a vehicle of transmission of cholera. *Journal of Diarrhoeal Disease Research.* **17**:1–9.
10. Tien JH and Earn JD, 2010. Multiple transmission pathways and disease dynamics in a waterborne pathogen model. *Bulletin of Mathematical Biology.* **72**: 1506-1533.
11. Tien JH, Poinar HN, Fisman DN, and Earn DJ. 2011. Herald waves of cholera in nineteenth century London. *Journal of Royal Society Interface.* **8**:756–760.